

Marbles and other ornamental stones from the Apuane Alps (northern Tuscany, Italy)

Carmignani L.¹, Meccheri M.² & Primavori P.³

¹Dipartimento di Scienze della Terra, Via Laterina 8 - 53100 Siena (carmignani.luigi@unisi.it)
and Centro di Geotecnologie, Via Vetri Vecchi, 34 - 52027 San Giovanni Valdarno (Arezzo)

²Dipartimento di Scienze della Terra, Via Laterina 8 - 53100 (meccheri@unisi.it)

³Geologist, Via Prinetti, 19 - 56124 Pisa (pieprima@tin.it)

ABSTRACT. This paper aims to offer a general view of the ornamental stones of commercial interest present in the large outcrops of the Apuane Alps Metamorphic Complex. Apart from the worldwide known white marbles, other rocks quite used for both decorative and building applications are variously coloured metabreccias and calcschists, metasandstones and minor phyllites. The physical and microstructural features of the lithotypes are shortly described as the heritage of the tectono-metamorphic evolution suffered by them during the Tertiary Alpine-Apennine orogenesis. Their meso- and microstructural setting (particularly of the marbles) are discussed in relation to the problems of cutting measures in the open-sky or underground quarries, in order to obtain the most decorative products.

Key terms: Apuane Alps, Marbles, Ornamental stones, Mesostructure, Microfabric, Quarry front, Underground exploitation

General Geological Overview

The Apuane Alps are a worldwide known region because of large outcrops of ornamental stones, among which the whitish and variously ornated marbles are the most famous and have been exploited since the first century B.C. (DOLCI, 1980).

In the regional context of the inner northern Apennines, the Apuane Alps are an uplifted and severely eroded region (the "Apuane core complex", Carmignani & Kligfield, 1990) in which the Tertiary fold-and-thrust structure of the Apennine chain is best exposed. The deepest part consists of the so-called Apuane Metamorphic Complex (here after AMC) that comprises the metamorphic sequences of the Massa Unit and the underlying Apuane Unit (ex Autochthonous *Auctorum*); as the latter includes almost all of the ornamental stones here concerned, our attention will focus on it. Upwards the AMC is followed by unmetamorphosed cover units, that is, the Tuscan Nappe, the Canetolo Unit, and some units from the Ligurian Domain, named Liguride Units *sensu lato*.

The lithostratigraphic sequence of the Apuane Unit is formed by the following main groups of metasediments:

- Middle-Late Triassic to Early-Middle Liassic metadolostones, dolomitic marbles and pure marbles;
- Middle Liassic to Early Cretaceous cherty metalimestones, metacherts and calcschists;
- Early Cretaceous to Early Oligocene phyllites and metasilites, locally containing marble interlayers, calcschists and lenses of metacalcarenites;
- Late Oligocene to very Early(?) Miocene quartz-

feldspathic micaceous metasandstone.

This sequence was deposited over a portion of the paleo-African margin, and during the Tertiary both the Alpine cover and its pre-Alpine (Hercynian) basement were involved in the Alpine orogenesis through two, syn-metamorphic, main tectonic events.

The first deformation phase (D₁), active at the Oligocene-Miocene boundary (between about 30 and 25 My), was compression-related and caused the above-said tectonic units to pile up. The rocks of the Apuane Unit suffered severe deformation through development of a penetrative foliation (S₁), axial planar to NE-facing, sub-millimetric to pluri-kilometric isoclinal folds coeval to a green schist facies metamorphism. The evolution of this phase led to (1) several laminations along the flanks of the folds, (2) widespread elongation lineation parallel to the S₁ (stretching of clasts, fossils, etc., boudinage, linear preferred orientation of metamorphic minerals), (3) increasing development of sheath geometry in the fold style passing from WSW to ENE. At the regional scale and along a W-E cross section from the contact with the overlying units (to the West) to the lowermost structural levels (to the East), the main megafolds of the Apuane Unit are the Carrara Syncline, Vinca-Forno Anticline, Orto di Donna-Mt. Altissimo Syncline, Mt. Tambura Anticline and many kilometric synclines and anticlines of the Vagli-Mt. Sumbra sector.

The following tectonic phase (D₂) began in Early Miocene (nearly 25 My ago) as a consequence of the tectonic regime inversion from compression to extension. This made the piled units progressively uplifted in junction,

since Late Miocene, with the first openings of the eastern Ligurian and Tyrrhenian Seas. This uplift resulted in a large-scale positive structure (the Apuane "dome") characterized by a complicated internal geometry and a NW-SE lengthened shape. The most frequent D_2 structures are variously sized folds, with axial planar foliation (S_2) accompanied by a green schist facies blastesis retrogressive with respect to the syn-late D_1 imprinting. On the whole, these folds form staircase sets diverging from the main hinge zone of the regional megastructure toward both SW and E-NE along the SW and NE slopes of the "dome". These folds are often related to several, ductile to ductile-brittle shear surfaces whose kinematics matches the vergence of the same folds.

During the final stages of the Apuane uplift, the extensional structures gradually changed from mainly ductile to brittle, that is, high angle normal faults trending both NW-SE and less frequently SW-NE. They were likely related to the development of the Versilia-Vara, Lunigiana and Garfagnana-Serchio tectonic depressions bordering the Apuane Alps high to the SW, NW and NE-E (respectively).

The Ornamental Stones

In addition to marbles, the Apuane Alps provide other ornamental rocks such as metabreccias, "cipollini" and metasandstones. All these rocks are seldom quoted as "Apuane marbles", so it is worth specifying that:

- the marbles only correspond to the Lower Liassic Marble *s.s.* formation of the Apuane Unit sequence;
- metabreccias are metarudites principally pertaining to stratigraphic horizons older or younger than the Marbles *s.s.*, but to some extent also to the latter (the "arabesque" type, see later);
- the "cipollini" are calcschists that form thick and persistent bodies corresponding to younger formations, and a few thin levels also at the Marble *s.s.* top ("zebrino", see later);
- finally, the Upper Oligocene flysch is exploited for production of metasandstones and dark gray/blackish metasiltites and phyllites.

Stones from the Marble sensu stricto formation

Quantitatively and industrially most important, the Marble *s.s.* formation offers some commercial types that are clearly defined for the entire extension of this formation all over the Apuane Alps, but very often they are given particular names of only local use; moreover, in some areas minor and particular sub-types crop out enriching the general list, and they will be recalled each time.

Referring to the most known and exploited Marble *s.s.* outcrop in the Apuane Alps, the Carrara inland, whose commercial types are shown in a recently published thematic map (CARMIGNANI et alii, 2003), the main varieties are the following:

- "Marmo ordinario" (ordinary marble, FIG. 1A): fine to mid-coarse grained metalimestone, more or less homogeneously pearl-white colored or with gray tiny spots and thin, short veins, irregularly distributed and due to locally concentrated pyrite microcrysts. In many places this variety is almost identical (with respect to color and decoration) to the "Marmo venato", hence it is often difficult to draw a valid boundary in-between.
- "Marmo venato" (veined marble, FIG. 1B): mid-grained, pearl-white to light gray metalimestone, with a fairly regular network of more or less dark gray veins corresponding to centimeter- to millimeter-thick belts of concentrated pyrite microcrysts. On the whole, this variety comprises many sub-types whose aspect and structure range from an unreworked metabreccia to almost regular compositional alternations, the latter representing probable relics of the original bedding.
- "Marmo nuvolato" (cloud-like marble, FIG. 1C): fine to mid-grained gray metalimestone crossed by numerous, more or less marked, light gray to whitish veins and irregular strips. Variably widespread microcrystalline pyrite is responsible for the variegated gray color. This variety often includes more homogeneous gray bodies or metabreccia lenses, respectively resembling the "bardiglio" and "arabescato" types.
- "Marmo arabescato" (arabesque-like marble, FIGS 5 and 7): grain-supported metabreccias with predominant clasts and boulders of white to gray marbles in a minor, more or less dark gray carbonatic matrix; the fragments mainly derive from ordinary, veined and "nuvolato/bardiglio" types. An appreciated sub-variety is the "Marmo brouillé" characterized by well-marked gray matrix in veins thicker and more persistent than in the normal "arabescati".
- "Marmo statuario", "Statuario venato" (statuary marble, veined statuary): very pure coarse-grained metalimestone, ivory-white to very light yellow-cream colored due to a homogeneous distribution of microcrystalline muscovite. In some places, small and sparse pale gray spots (microcrystalline pyrite) modify such a constant composition. Locally, the pyrite concentrations become more abundant and, together with some major amounts of phyllosilicate (muscovite and chlorite) form widespread, anastomosed thin veins giving the veined statuary sub-type.
- "Marmo Calacata" (Calacata marble, FIG. 1D): the name derives from the locality Calacata (N of Torano village) where this variety is mostly exploited. It is a grain-supported metabreccia with very light white-yellowish marble clasts, seldom containing light greenish veins, and a minor, muscovite-chlorite rich carbonatic matrix more green and yellow-ochreous coloured than the clasts. A sub-variety is the so-called "Calacata macchia oro" (gold-spotted Calacata), characterized by almost absent muscovite, chlorite and pyrite and differing from the statuary only in its feeble ochreous-golden veins and diffuse spots.

- "Marmo bardiglio" ("bardiglio" marble): fine grained metalimestone characterized by a gray color more marked and homogeneous than the "nuvolato", due to abundant microcrystalline pyrite. Several, usually dark gray to

blackish veins are frequent, locally forming a sub-variety known as veined "bardiglio"; dolomitic levels may be present as well.

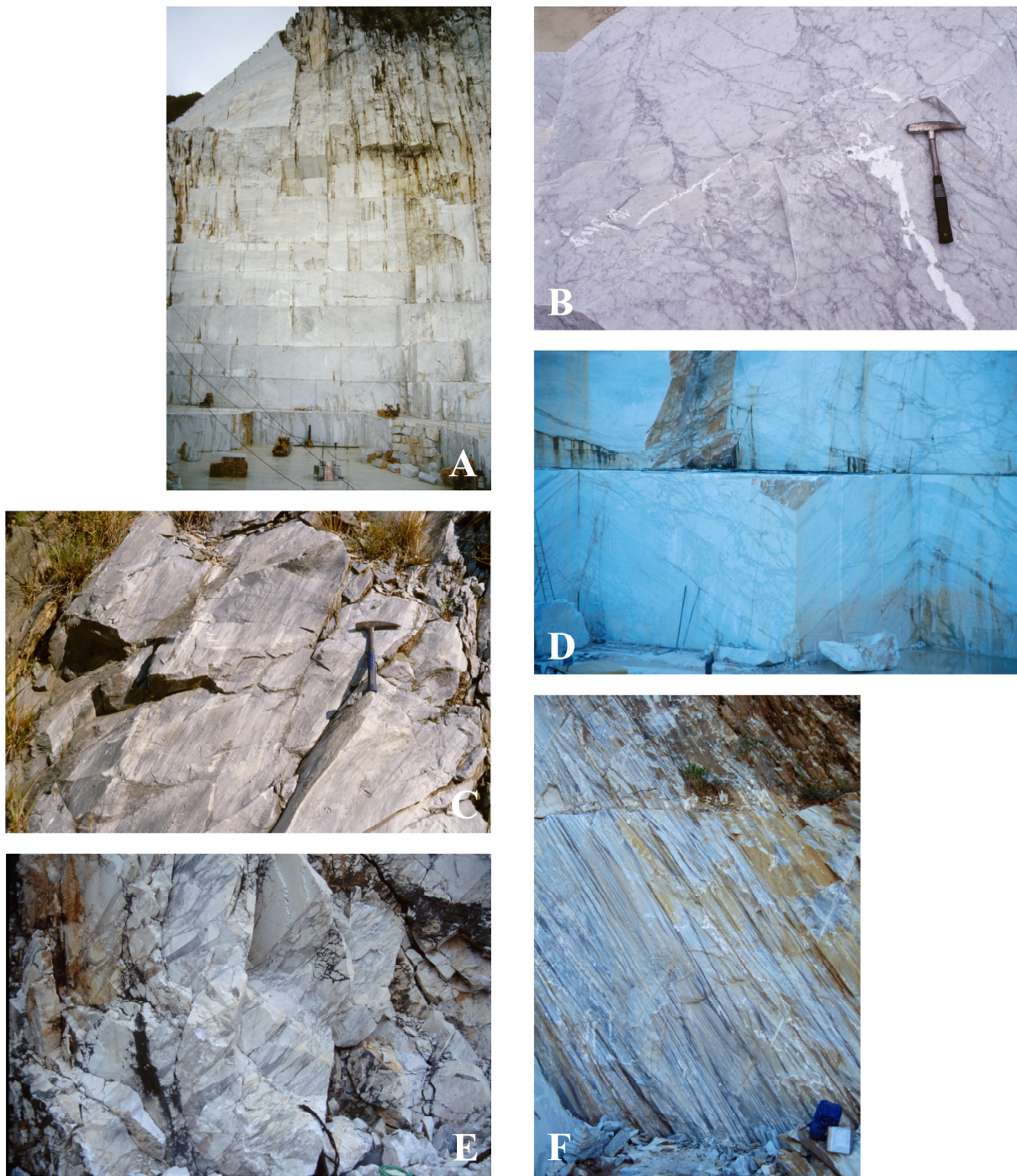

FIG. 1. A: "Marmo ordinario" with minor light veined levels at Ortensia Quarry north of Colonnata (total height more than 100 m). B: regularly ornated "Marmo venato" from the Fantiscritti area. C: natural aspect of the "Marmo nuvolato" from Tarnone locality in the Colonnata valley. D: the Calacata variety of the Ruggeta Quarry near Torano village. E: a rare example of "paonazzo"-like metabreccia cropping out at Carpevola, Ponti di Vara (Miseglia valley). F: the thin, almost regular primary layering of the "Marmo zebrino" deformed by very tight D_1 folds, from a quarry close to Ponti di Vara.

In the Carrara area two more types can be added to the principal ones, but they are almost worked out or in negligible amounts:

- "Marmo paonazzo" (purple-violet marble, FIG. 1E): a metabreccia with clasts chiefly derived from statuary and/or Calacata types, and a minor, phyllosilicate-rich, gray-blackish to red-violet matrix; in the latter, Fe-minerals are abundant, whose alteration causes the often widespread, characteristic purple-violet pigmentation of the clasts.
- "Marmo zebrino" (striped marble, FIG. 1F): the last variety consists of dm-thick layers of white-yellowish marbles regularly alternated with thinner beds of chlorite-muscovite-rich gray-greenish metalimestone. At places, the carbonate is either more mingled with the phyllosilicates, generating a sort of calcschist, or concentrated to form rare decametric bodies and lenses of coarse-grained, almost pure marbles, very similar to the statuary and named "Crema delicato" (light cream-colored marble).

Among these marbles only the "ordinari", "venati", "nuvolati" and "arabescati" can be found (though in markedly diverse amounts) in every exploitation district of the Apuane Alps:

- "Marmo ordinario" of good to very good quality is from all the localities and represents the bulk production from the Apuane marbles as a whole. Noteworthy are (1) the "bianco P", famous for the almost total absence of veins, today more or less totally worked out but, maybe, still with tiny bodies in the Carrara, Massa and Vagli areas, and (2) some very homogeneous and fine-grained white ordinaries from Carrara, Massa, Equi, Gorfigliano, Vagli, Mt. Altissimo and Mt. Corchia;
- because of their marked resemblance to the "ordinari", the "venati" are diffusely present, we can mention only the "venato forte" (heavy veined) and "venato debole" (light veined) sub-types (COLI et alii, 1988), the difference being the major or minor (respectively) darkness, thickness and persistence of the vein framework crosscutting the whitish-light gray bulk rock. The "venato debole" type is quarried in many places and the whole production is comparable to that of the "ordinari", whilst the "venato forte" comes from some marble levels in the Orto di Donna (Gramolazzo), Mt. Altissimo and Passo della Focolaccia (Gorfigliano) districts (very rarely from other areas);
- the "nuvolati" form large bodies with no particular distribution inside the major "ordinari" and light "venati" types (Carrara, Massa, Seravezza, Mt. Corchia and Panie group), or thick beds alternated with "ordinari" and heavy veined levels (Orto di Donna, Mt. Altissimo and Passo della Focolaccia) to form a kind of well-developed primary stratification. Probably due to the low commercial request, in the last fifteen-twenty years the "nuvolati" production has been rather scarce;

- on the contrary, the "arabescati" are intensely exploited in almost every zone, because they frequently combine decorative beauty with high-quality physical-mechanical features, thus being used in a wide range of internal and external applications. The ornamental variability of the "arabescati" slabs and works is very high thanks to clast-matrix chromatic combinations and clast size-shape patterns (see later), and thus several sub-types come from the various districts and are distinguished on the basis of exclusive color-ornament characters: many kinds and the "brouillé" marble from Carrara; the "arabescato" Arnetola from Vagli and the "arabescato" Faniello from Arni; the Altissimo, Cervaiolo and "breccia" Rio Serra from the southern Mt. Altissimo; the "arabescato" Corchia, etc.

Regarding the other varieties:

- in the Carrara area the "statuari" and veined "statuari" give the widest and most continuous levels, but interesting though scattered outcrops are also present in the Massa inland and in the Mt. Altissimo region;
- the Calacata types are almost all confined to the Carrara inland as well, but in other zones minor bodies are associated with the "statuari" or crop out as particular variations of local "arabescati", e.g. the Calacata Arnetola (Vagli);
- conversely, the "bardigli" and veined "bardigli" are more regularly present in all the Apuane marbles and, though forming usually restricted lenses, they give locally important types among which the best known is the "bardiglio" Cappella near Seravezza.

The metabreccias

Apart from the "arabescati", "calacata" and "paonazzo" pertaining to the Marbles, we can mention the Seravezza Breccias (Fig. 2A) deriving from a discontinuous Late Triassic formation stratigraphically at the top of the "Grezioni" dolomitic formation, and whose largest outcrops are in the Seravezza inland, southern Apuane Alps. These are grain-supported, medium- to coarse-grained metabreccias formed by calcitic and minor dolomitic clasts, with variable color, size and distribution, in a usually scarce matrix made up of muscovite and calcite-muscovite often with fine chloritoid crystals, plus minor amounts of hematite and chlorite and local additions of quartz, dolomite, and microphyrite. In the past they were intensely quarried in several places, but now the various levels are almost worked out; these stones provided magnificent, highly colored slabs widely used in internal ornamentation and construction (floors, staircases, columns, etc.).

Other commercially important metabreccias are provided by some horizons stratigraphically younger than the Marbles s.s. and mainly cropping out in the Arni and Arnetola (Vagli) districts. Some commercial names of these stones are "arabescato Vagli", "breccia rossa Arnetola", "arabescato Arni": they are grain-supported coarse-grained metabreccias (FIG. 2B) with clasts of only whitish marble in

a variably scarce calcareous-phyllitic to phyllitic (muscovite and chlorite), dark green-gray to gray-purple matrix.

The "cipollini"

As already said, in general these stones are calc-schists constituted by whitish to light yellowish marbles in which green, gray-green, gray and gray-brown anastomosed veins of chlorite/muscovite (plus traces of quartz, dolomite and other minerals) draw a highly complex structural geometry. The most common aspect is given by dm- to cm-thick marble levels and lenses separated by mainly chloritic phyllites/carbonatic phyllites forming persistent, cm-thick strips and/or submillimetric films. On the cut slabs this pattern results in remarkably diverse drawings and decorations depending on cut orientations with respect to the rock 3/D structure in the measures.

Another type has very small patches and/or thin short veins of phyllosilicates finely and almost regularly scattered within the dominant calcitic component, thus giving a relatively appreciated light green to green-grayish stone.

These rocks mainly belong to the Cretaceous-Eocene

metamorphic "Scaglia Toscana" and are exploited in the districts of Gorfigliano, Arnetola and Boana (Vagli), Arni and Isola Santa in the north-east Apuane Alps, and at Volegno in the southern Apuane Alps; a classic example is the "Fantastico Arni" (FIG. 2C) from north of Arni village. Other minor horizons of very similar stones are interlayered in the early Cretaceous crinoid-bearing cherty metalimestones and the Malm metaradiolarites, but they frequently bear small nodules and/or thin lenses of quartzites that reduce the commercial value of these stones.

Stones from the upper Oligocene flysch

The flysch here concerned is a quartz-feldspathic biotite metasandstone, the metamorphic counterpart of the Macigno in the unmetamorphosed Tuscan sequence. This formation crops out in two large regions, the Stazzemese zone and the area between the Vagli Lake and the Turrite Secca Valley, respectively in the southern and eastern Apuane Alps; minor and dispersed levels are also found between Arni and Vagli and near Minucciano (north-east and northern Apuane).

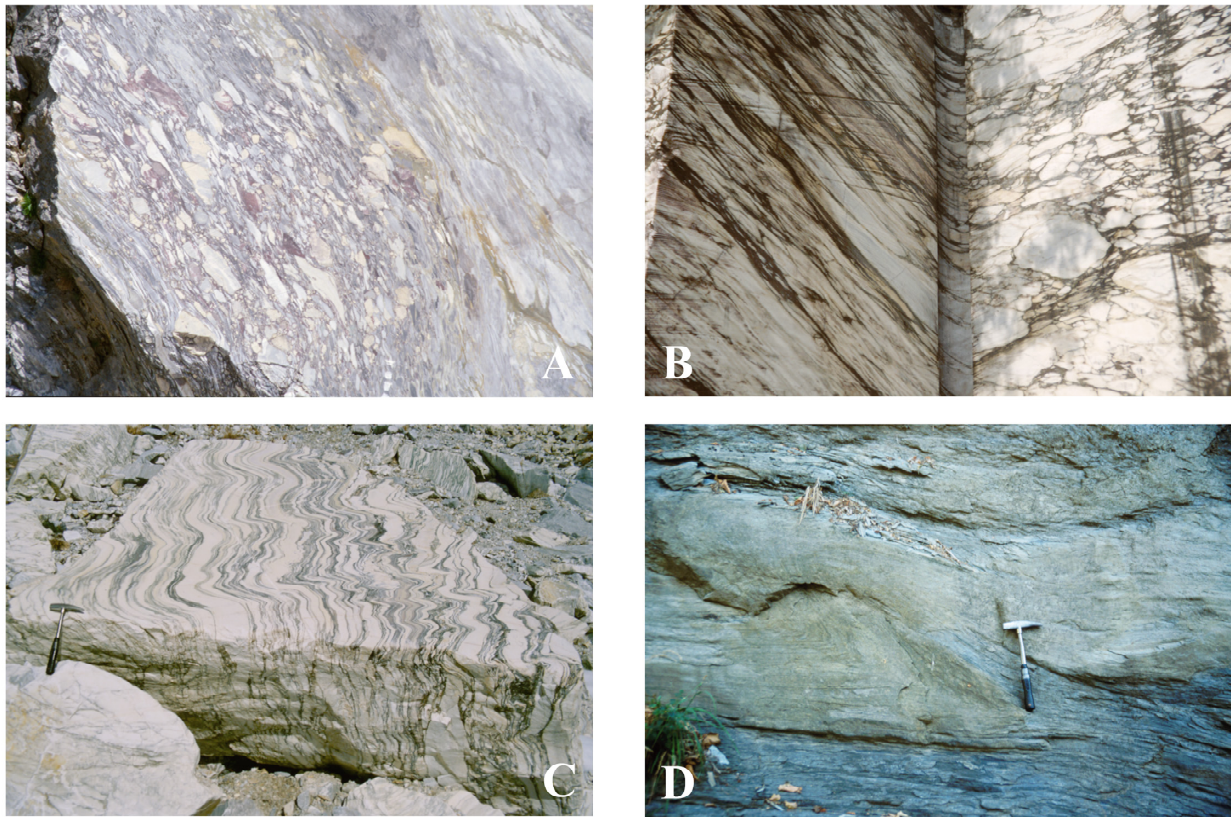

FIG. 2. A: varied bright colours of the Seravezza metabreccias from Mt. Corchia, southern Apuane Alps. B: typical aspect of the post-marble metabreccias from the Borella area, Vagli, northeastern Apuane Alps. Where the clasts have scattered pale rose-reddish to whitish colours, this stone is very appreciated and named "pesco fiorito" (= flowered peach-tree). C: "cipollini" measure from the Arni valley (central Apuane Alps) with scattered and highly variable decoration that suggested the name "fantastico Arni". Note that often the "levels" are ultra-stretched marble clasts, as the reader can observe in the frontal vertical surface of the block. D: D_2 phase metric folds deform alternating metasandstone ("Pietra del Cardoso") and phyllite ("Ardesia apuana") levels of the Late Oligocene Pseudomacigno formation from the Cardoso surroundings, Stazzema (southern Apuane Alps).

The only important exploitation district is the first one, in particular in the surroundings of the village of Cardoso, where several quarries produce the so-called "Pietra del Cardoso" (Cardoso stone) and the "Ardesia apuana" (Apuane slate) (FIG. 2D). The "Pietra del Cardoso" is a typical coarse- to fine-grained, gray to dark gray metasandstone with clasts strongly flattened and stretched along the main local foliation (almost everywhere the S_1); the foliation is usually very pervasive and allows the rock to be easily split in rough but almost planar large slabs with high cohesion and strength.

The "Ardesia apuana" represents the metasilite-metapelite intervals of the primary thick turbiditic sequence; due to laminations and/or squeezing phenomena during the Tertiary synmetamorphic deformation, these phyllites are either absent in large volumes of metasandstones, or concentrated to form metasandstone-free lenses, a structural setting suitable for the best exploitation of the two rocks.

Finally, the schematic list below provides a quantitative share of the currently exploited varieties in the Apuane Alps:

- "Marmo ordinario" 53.5%;
- "Marmo venato" 24.8%;
- "Marmo statuario" ~ 4%;
- "Marmo Calacata" ~ 3.5%;
- "Marmo brouillé" ~ 1.4%;
- "Marmo bardiglio" ~ 3%;

- "Marmo nuvolato" ~ 1.5%;
- "Marmo arabescato" ~ 2.9%;
- "Marmo zebrino" (including "Marmo paonazzo" and "Crema delicato") ~ 0.4%;
- Metabreccias: 1.3%;
- "Cipollini" 0.9%;
- "Pietra del cardoso and "Ardesia apuana" 2.7%;
- Others: 0.1%.

Relationships between Geological Features of the Rocks and their Use as Dimension Stones: Examples from the Apuane Alps Marbles

Although the Apuane marbles have been known and used, with relevant results, since the Roman Empire period, the increasing knowledge of their lithologic, geometric and structural characteristics has allowed their excavation and their applications to be consistently improved and refined. Many investigation aspects have received a considerable impulse over the last years; among them, the relations between the marble structural (macro and micro) features and the methodology of excavation, and between the marble microfabric and performance after application are most important. Some examples of relationships between the geological setting of the Apuane marbles and their use as dimension stones are given below.

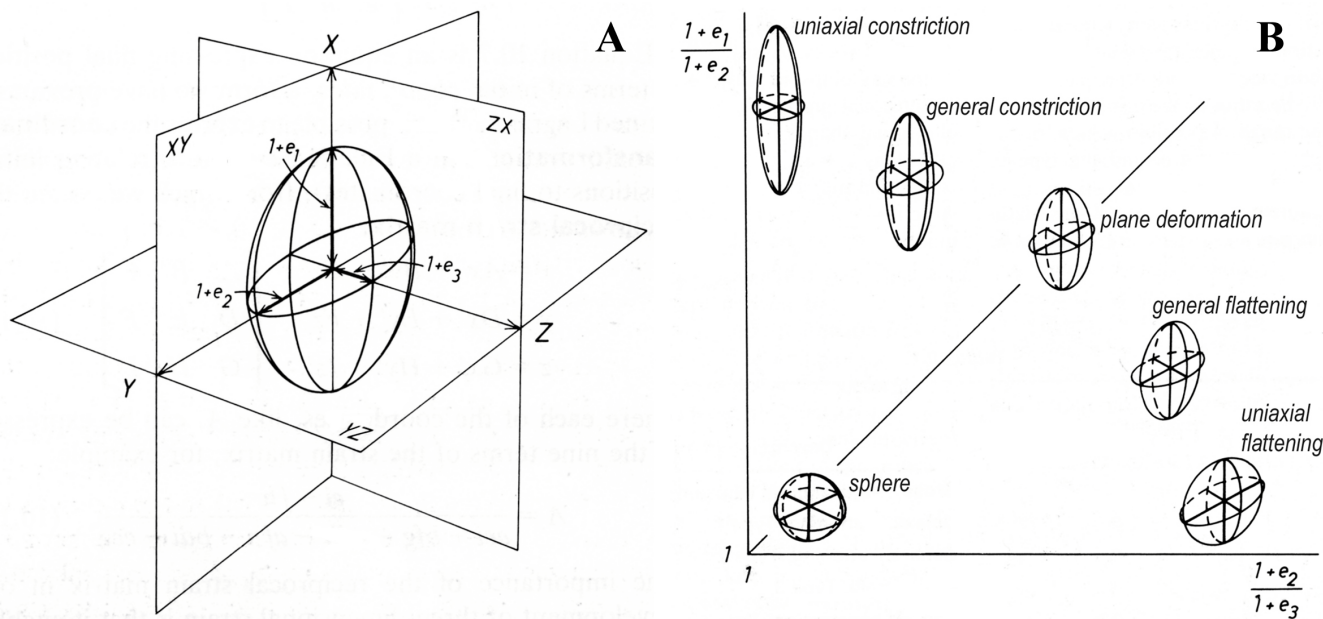

FIG. 3. A: the deformation ellipsoid. X, Y and Z are the principal deformation axes, along which the extension (positive or negative) is represented by the notations $(1+\epsilon_1)$, $(1+\epsilon_2)$ and $(1+\epsilon_3)$; XY, YZ and ZX are the principal deformation planes. B: shows a Flinn representation of the deformation ellipsoids; R_{yz} and R_{xy} are plotted on the X and Y axes (respectively). The origin of the graph is necessarily (1,1) since, by definition, the value of R cannot be lower than 1. The origin represents the reference sphere. Every ellipsoid is represented by a point within the positive area of the graph.

Relations between the fabric and the ornamental features of the Marble s.s.

It is well known that the relations between the orientation of specific surfaces inside the rocks (schistosity, bedding, magmatic fluidality, etc.) and the orientation of the cuts in the quarry (both at the quarry front and in the blocks) are crucial for the blocks to show an aesthetic pattern which is accepted by the market. In particular, the decorative aspect of highly deformed rocks is strongly related to the type and the features of the acquired structure.

Differences may be marked enough to provide completely independent commercial varieties from the cut of the same rock. It is also possible that one rock acquires or loses commercial value according to the orientation of its cut. In order to properly appreciate how important is this phenomenon in the Apuane marbles, it is convenient to recall some basic concepts of Structural Geology.

Plotting the ratios $(1+\epsilon_2) : (1+\epsilon_3)$ and $(1+\epsilon_1) : (1+\epsilon_2)$ respectively on the X and Y axes of a coordinate system, we achieve a tool (the Flinn diagram, FIG. 3B) to represent all the possible finite deformations through the related ellipsoids.

In FIG. 4 three examples of very common finite deformations are shown. In A, the rock suffered contraction along two main axes and elongation along the third axis, and the resulting structure is a L-fabric represented by a sigar-like (prolate) ellipsoid. In C, contraction was along

only one main axis, while along the other two main directions the rock was elongated, thus the resulting structure is a S-fabric represented by a pancake-like (prolate) ellipsoid. Obviously, the B example corresponds to an intermediate type of finite deformation.

In fine-grained rocks the fabric is visible only with a careful observation or in thin section but, when metaconglomerates, metabreccias and fossiliferous rocks are involved, the figurative elements may constitute the leitmotif of the decorative aspect.

In these cases the orientation of the cut is absolutely crucial. Different commercial varieties can be obtained from the same rock simply by varying the orientation of the cut with respect to the orientation of the deformation ellipsoid. In the case of many highly deformed Apuane metabreccias, the cut parallel to the plane XZ will provide a "listato" (striped) marble, whilst the cut parallel to the plane XY will provide extremely elongated breccia elements (FIG. 5). Rocks with an L-fabric (prolate ellipsoids, FIG. 6) have a few and poorly effective cleavable planes ("verso"), while rocks with an S-fabric (oblate ellipsoids) have a more marked cleavability or schistosity ("verso"). Should they contain a significant amount of chlorite and/or phyllosilicates, possibly concentrated in specific levels, to cut them into slabs will be very difficult ("macchia lente"). On the contrary they can be profitably split mechanically.

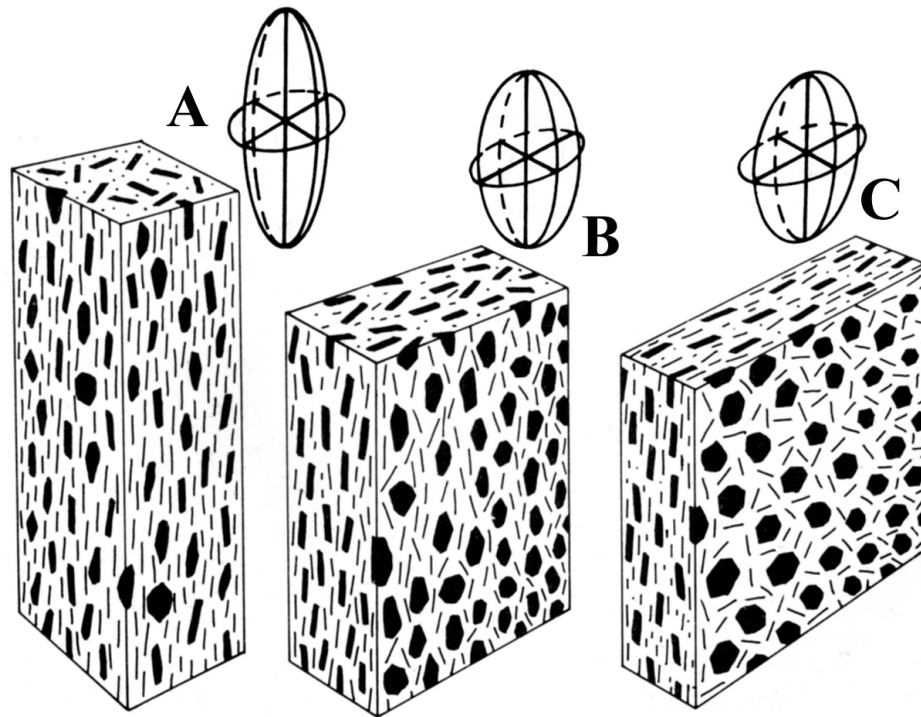

Fig. 4. Different structures due to different types of deformation. The three examples refer to sections parallel to the main surfaces XY, YZ, XZ of the ellipsoid. A: prolate ellipsoid; B: plane deformation; C: oblate ellipsoid, see text for explanation. From Ramsay & Huber (1983), modified.

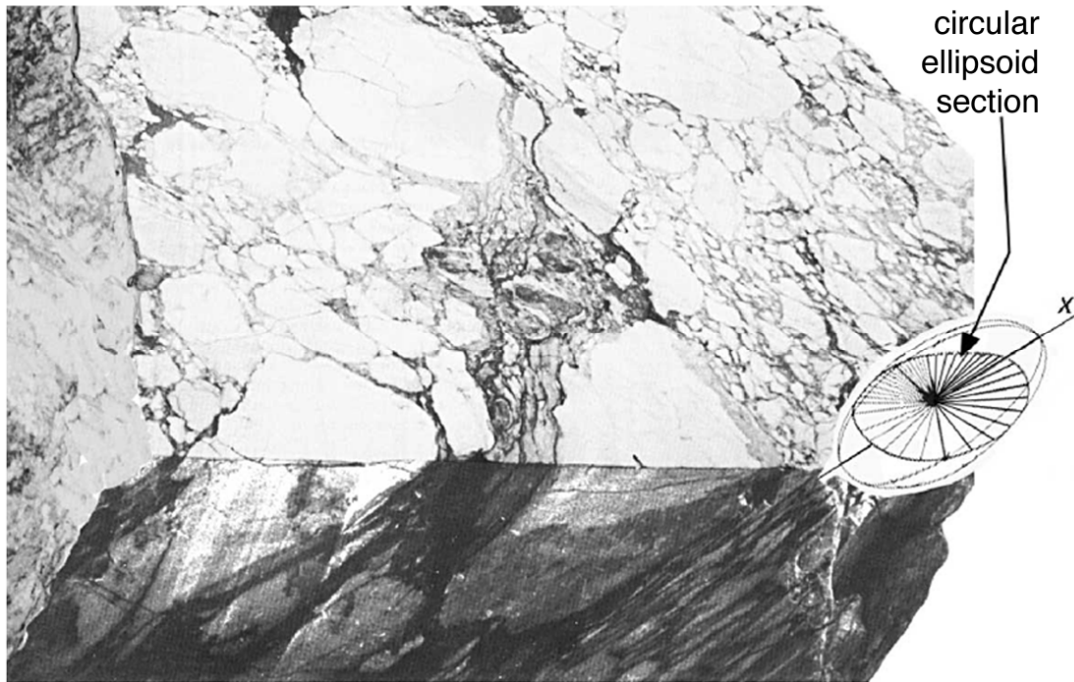

Fig. 5. Block of “Marmo arabescato”. The clasts of this metabreccia are clearly flattened parallel to the plane XY along the vertical cut (lower portion of the photo, in the shadow), and without any appreciable preferential orientation along the other cut (upper portion of the photo, in the light). In many “arabescato” quarries the blocks are extracted with cuts parallel to one of the two main sections of the deformation ellipsoid to provide slabs with a non-oriented ornamental pattern. From Ramsay & Huber (1983), modified.

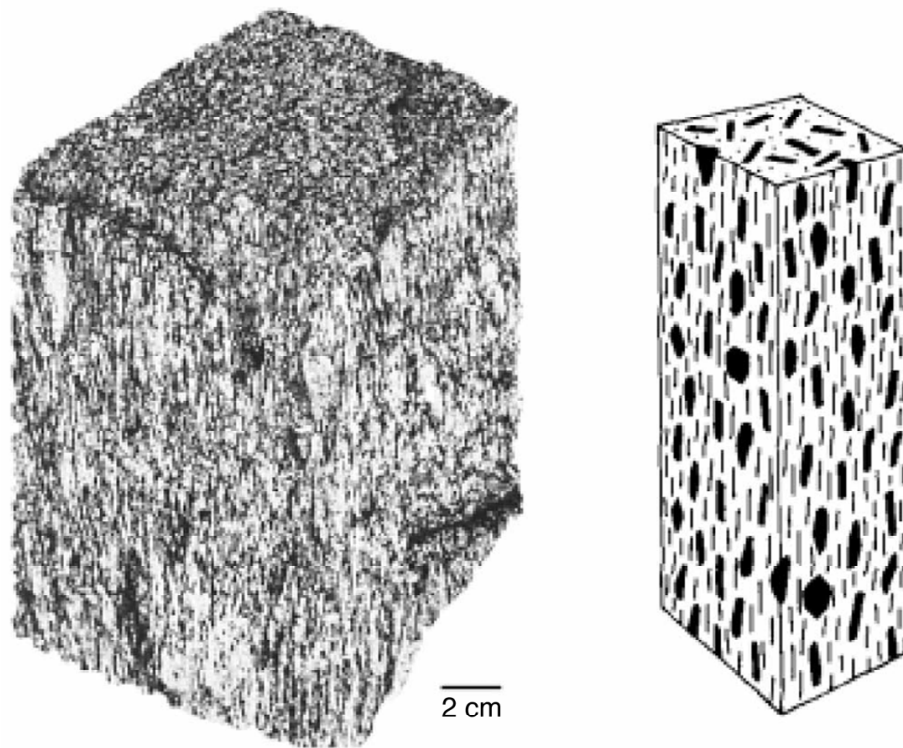

Fig. 6. Example of a linear fabric (L-fabric) in a gneiss. Lateral faces of the prism contain the direction X of the ellipsoid of the deformation; the bases are orthogonal to this axis. From Ramsay & Huber (1983), modified.

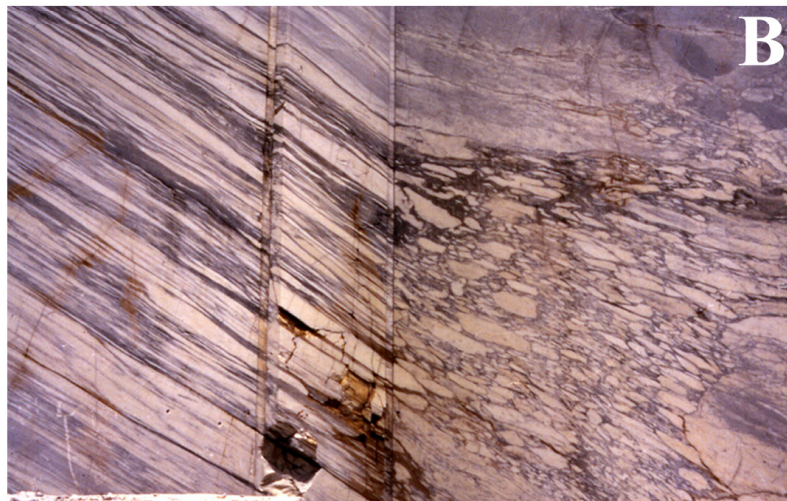

Fig. 7. A: shapeless block of Corchia “arabescato”. Left: aspect not accepted by the market; right: aspect accepted by the market. B: vertical quarry front in the Corchia “arabescato” (Tavolini Quarry, Mt Corchia). Left: aspect not accepted by the market; right: aspect accepted by the market. Note that the orientation difference between the two surfaces is only 10°.

A marked orientation is sometimes a highly desirable feature which can be given the maximum commercial value with a proper and accurate installation of the slabs (or tiles). This is what generally happens when the elements of a floor, or a cladding, are arranged giving all the slabs (tiles)

the same orientation, so as to recreate in the final installation the same regularity and naturalness that can be observed on the blocks. In the so-called “book-match” pattern, the stone elements are installed to create a specular appearance between adjacent pieces. On the contrary, if a

clear orientation is not required, the metamorphic rocks showing an oriented fabric must be cut obliquely to the extension axis X and parallel to a circular section of the deformation ellipsoid (FIG. 5).

This surface does not show any preferential orientation and the figurative elements (e.g., the clasts) maintain their undeformed original aspect prior to deformation. Commercial operators and quarrymen tend to name the marble cut along these planes “fiorito” (flowered), since the elongated aspect of the elements “expands”.

Apuane Alps constitute an excellent example of the fabric-ornamental features ratio. Due to the strong deformation occurring in the whole metamorphic sequence (CARMIGNANI et alii, 2003), a minimum change in the cutting orientation may give the marble an attractive appearance or, alternatively, an aspect totally rejected by the market (PRIMAVORI, 1999) (FIG. 7).

Although the quarrymen have an immense capacity to locate the surfaces which give the marble the aspect and the pattern required by the market, it is indisputable that the current level of knowledge in terms of geometry of the folds, deformation style and structural reconstruction of the metamorphic sequence has increased the possibility to properly guide quarry exploitation. In those quarries where the aspect of the marble is absolutely crucial for its marketability (particularly the “arabescato” varieties), the decisions concerning the development of the excavation, the orientation of the quarry fronts, the cutting directions of the commercial blocks are intimately related to the geological-structural features of the rock.

Relations between the Marble s.s. structures and the methodology of underground excavation

Due to environmental pressures and the growing difficulties experienced in many open-sky quarries, underground exploitation is more and more frequent (FORNARO & BOSTICCO, 1998). At a worldwide scale, the Apuane district is the area where the highest number of underground quarries occurs; it is also the area where the greatest experience in managing such a type of activity has been acquired.

Knowledge of the geo-mechanical characteristics of the rock is fundamental in planning quarry work since the

consequences of poor performance of the rock can never be evaded. Whereas in open-cast quarrying certain problems or difficulties can substantially be overcome by “last-minute” decisions, potential problems should be tackled in advance underground, otherwise there is the risk of heavy penalties in terms of both work economy and safety (FORNARO & BOSTICCO, 1998).

The orientation of the quarry-face selected for the initial cuts of a future underground quarry can theoretically be any; in reality, the decision for the selection of the most appropriate face where the operations must start is intimately related to the structural setting of each deposit. Fracture systems, schistosity (“verso”) and two other related surfaces (“contro” and “secondo”) are the elements which determine where and how to start underground exploitation. A detailed reconstruction of the structural geology (brittle and ductile) is absolutely crucial to properly plan the beginning phase of the underground quarry (and its continuation, of course). We would like to remind readers who are possibly poorly informed about dimension stone quarrying that the expression “initial phase of an underground quarry” may correspond to several years of activity, with the imaginable economic aspects related to that.

In order to better understand the initial situation of an underground quarry, it is useful to introduce some basic explanations. Typically, in the Apuane area, underground exploitation is the evolution of a former open-sky exploitation; the most common procedure is to start from a vertical face, whatever its height.

A chain saw machine is generally used to perform the first cuts (PRIMAVORI, 2004); unlike the open-sky quarry, where a big bench is isolated from the deposit, overturned onto the quarry yard, and squared into final commercial blocks, the underground initial stage directly provides commercial blocks. It is therefore evident that their size, their form and their aspect (veins, design-pattern, color) must be the ultimate one since further squaring operations would constitute an additional cost. Figure 8 shows the geometry of the first cuts performed with a chain saw machine. When extracting the first block, the back face must be detached by means of splitting devices (FIG. 9).

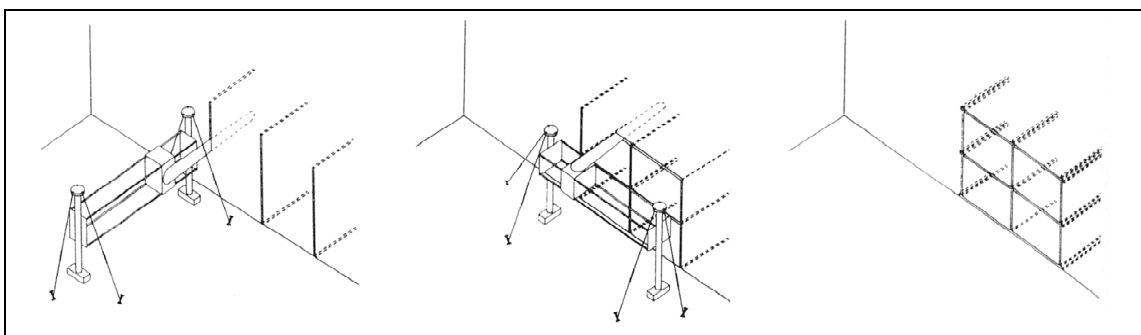

Fig. 8. Chain-saw machine executing the first cut in the underground exploitation.

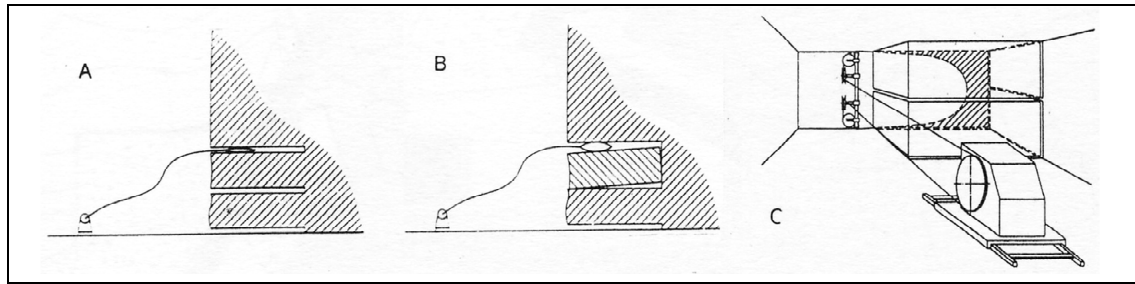

Fig. 9. A and B: detachment of the first block (section), the back face is detached by inserting a hydraulic splitting device in the upper (or in the lateral) cut. C: once the space is enough to install other machines, the diamond wire machine is also used.

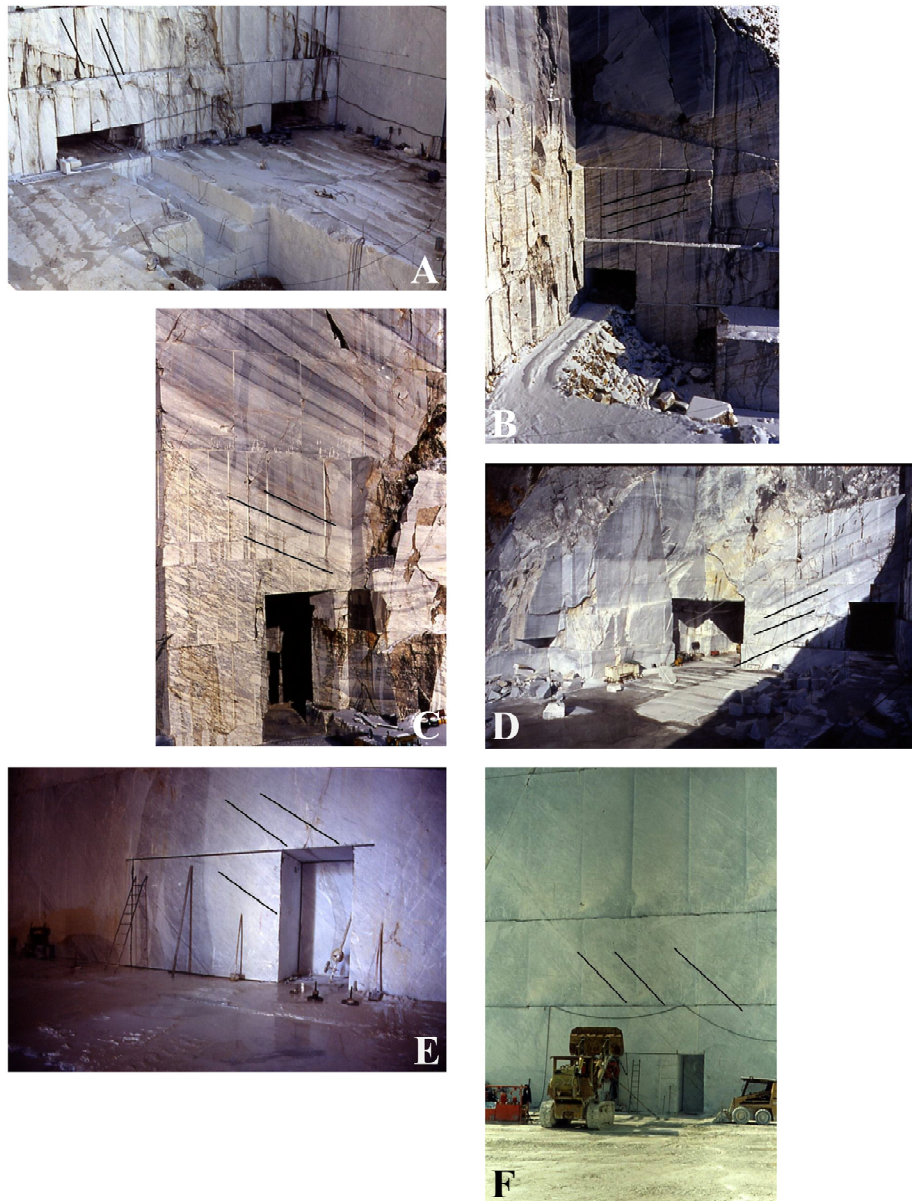

Fig. 10. Underground exploitation at the base of Mt Altissimo (A), the Tavolini Quarry (Mt. Corchia, B and C), and the Padulello Quarry (Massa inland, D). Examples of the initial stages of underground exploitation from Piastrone Quarry (Massa, E) and Gioia Quarry (Carrara, F). Black lines mark the “verso” orientation.

In order to obtain a regular detachment, the back surface must correspond to an easily cleavable plane. In most cases the plane along which the first block is split is the so-called “secondo” surface. In the Apuane Alps area, three peculiar surfaces are identified: the “verso”, the “contro” and the “secondo”; their terminology is a typical one, nowadays diffused all over the world with analogous terms.

The “verso” is the surface which splits most easily; it corresponds to the S_1 surface (schistosity S_1) in the Apuane marbles. It shows the minimum value of the mechanical properties (e.g. flexion resistance, compression resistance, etc.) and is often an undesired final surface which to obtain

the slabs from. Although there are some exceptions, blocks are rarely cut parallel to the “verso”.

The “contro” surface has the same strike as the “verso”, but an opposite dip. The two surfaces are, therefore, mutually orthogonal. “Contro” corresponds to the surface with the hardest splittability of the rock and is rarely selected as primary surface, both for mechanical and esthetical reasons.

The “secondo” is the third and last surface at right angles to the other two; it shows intermediate mechanical values and intermediate splittability.

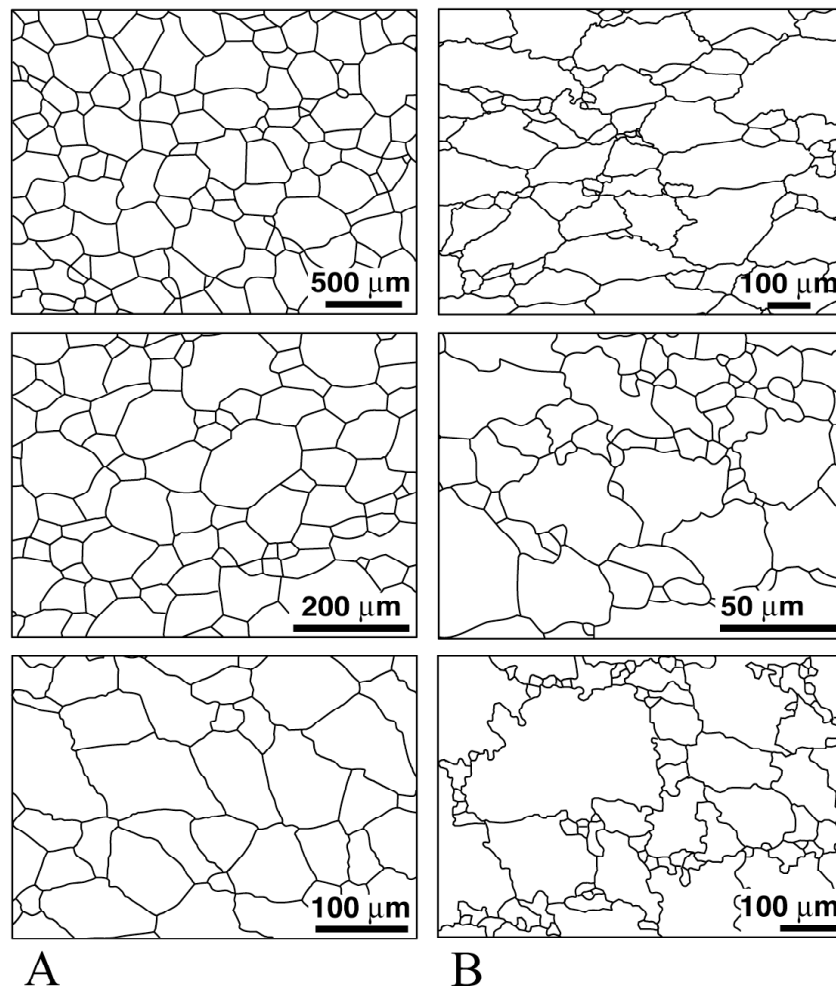

Fig. 11. Drawings of marble microfabrics (from Molli et alii, 2000, modified). A, examples of granoblastic microstructures: the grain boundaries are well defined, being straight or slightly curved, and with no optical evidence of crystal-plastic deformation. B, examples of xenoblastic structures: the grain boundaries are less defined, being sutured or embayed to lobate, the grain size is more variable and a grain orientation is sometimes appreciable.

These three surfaces are often associated with systematic discontinuities the names of which are “peli” of “verso”, “peli” of “contro” and “peli” of “secondo”. They constitute true physical discontinuities which must be followed during the exploitation. Since it is highly recommendable that the

back cut of FIG. 9 coincides with the “secondo” surface, it should be quite clear that, whenever and wherever an underground quarry is set up, it is indispensable to reconstruct the detailed geometry of the main schistosity (S_1

surface = “verso”) in order to intercept the “secondo” surface with the desired angle.

In the light of what has been previously described, it is also understandable that the correct orientation of the cuts depends on a relevant number of variables such as: the “verso”, “contro” and “secondo” orientation (variable from place to place, as a consequence of the polyphasic deformation of the Apuane marbles), the presence of the associated “peli”, the presence of eventual additional fractures, the existence of an initial vertical wall (quarry front) and further elements which depend on each individual quarry. Figure 10 shows some examples of initial underground exploitation where a “secondo” surface for the back splitting plane has been chosen.

Relations between the microfabric of the marbles and performances after installation

Important observations have been carried out concerning the relations between the microstructures of the marbles (FIG. 11) and their performances. Most of the studies dedicated to these aspects are still under development but the first issues are undoubtedly encouraging. One main aspect - the durability in external application - has been investigated in more detail by CANTISANI et alii (2000); other aspects, such as wear resistance, compression breaking load and flexural resistance, although not studied in a systematic way, have already been demonstrated to have some relations with the microstructures.

Durability appears to be related to the intimate microstructure of some marbles, particularly the granoblastic and xenoblastic structures, linked to distinct tectonometamorphic histories within the Apuane Metamorphic Complex (MOLLI et alii, 2000). In the granoblastic structures the grain boundaries are well defined, being straight or slightly curved, and with no optical evidence of crystal-plastic deformation; this structure is thought to be related to a static recrystallization associated with the D₁ phase (FIG. 11A). Instead, in the xenoblastic structures the grain boundaries are less defined, being sutured or embayed to lobate; the grain size is more variable and an evident grain orientation is appreciable. This structure is thought to be related to a dynamic recrystallization associated with the D₁ phase (FIG. 11B).

References

- BARSOTTELLI M., FRATINI F., GIORGETTI G., MANGANELLI DEL FÀ C. & MOLLI G. (1998) - *Microfabric and alteration in Carrara marble: a preliminary study*. Science and Technology for Cultural Heritage, 7, 115-126.
- BOINEAU A. & PERRIER R. (1995) - *La décohésion granulaire, maladie des revêtements de façades en marbles*. Mines et Carrières-Industries Minière, Août-Septembre 1995.
- BOSTICCO L., FORNARO M. & ORESTE P.R. (1993) - *Utilizzazione dei metodi numerici per la razionalizzazione dell'attività di coltivazione nelle cave sotterranee, con riferimento al marmo di Carrara*. Quarry & Construction, 6, 7-13.
- CANTISANI E., CANOVA R., FRATINI F., MANGANELLI DEL FÀ C., MAZZUOLI R. & MOLLI G. (2000) - *Relationships between microstructures and physical properties of white Apuan marbles: inferences on weathering durability*. Per. Mineral. 69, 257-268.
- CAPUZZI Q. (1988) - *La coltivazione del marmo in sotterraneo*. Centro Studi Ec. Soc. “C. Cattaneo”, Carrara.
- CARMIGNANI L. & KLIGFIELD R. (1990) - *Crustal extension in the northern Apennines: the transition from compression to extension in the Alpi Apuane core complex*. Tectonics, 9, 1275-1303.
- CARMIGNANI L., ANTONPAOLI M.L., BOCCI M., CHIEREGHIN F., FANTOZZI P.L., GRAZIOSI B., MECCHERI M. & SCIUTO P.F. (2003) - *Studi conoscitivi sui bacini marmiferi industriali di Carrara: un contributo per la gestione pianificata dell'attività. Cap. 3 - Il giacimento marmifero di Carrara e la geologia delle Alpi*

Significant difference between the two types of structures has been recognized in terms of mesoporosity (larger in granoblastic, smaller in the xenoblastic), saturation index (SI, higher in the granoblastic) and granulometric classes. Other significant parameters appear to be the surface area of the grains (A), the perimeter of the grains (P), long and short axes (L, S), and roundness (R_d) (CANTISANI et alii, 2000).

Since the durability of the marbles (in external applications) depends very much on the amount and manner of water absorption, marbles with granoblastic structures seem to show lesser durability. Their behavior with respect to thermal shock is also related to these structural features (BOINEAU & PERRIER, 1995). Marbles with xenoblastic structure and higher values of roundness seem to exhibit better resistance to weathering.

The results of the microstructural analysis can be also quite useful to determine the provenance of the marble (within the Apuane area) used in the past in sculptures, monuments, artistic works, historical buildings (CANTISANI et alii, 2000). In fact, when restoring decayed stones, it may be necessary to completely replace the old stones with new ones; in these cases it is fundamental to find the same lithotype or a stone which exhibits esthetical, technical and physical-mechanical characteristics as much similar as possible to those of the replaced stone.

As far as the wear resistance, compression breaking load and flexural resistance are concerned, no specific studies have been carried out up to date, but it is quite evident that they are related with the microstructures of the rock. Whenever the marble is characterized by complex grain boundaries, sutured or embayed to lobate, and a variable grain size, wear resistance is far higher than in marbles with more “common” granoblastic structures.

Effects on flexural resistance and compression breaking load are less evident (structural use is not frequent in the dimension stones), but all the descriptions of operators, consumers and technicians converge in the same sense.

Should these preliminary observations be confirmed by future studies, it would be of the utmost commercial utility to provide the owners of companies, the client and the end-users with this type of information.

- Apuane. Cap. 4 - Varietà merceologiche e strutture dei marmi del Carrarese. Cap. 6 - Il sistema informativo territoriale per la gestione degli agri marmiferi.*
- Quad. Studi Docum., 24, Suppl. GEAM, Anno XXXIX/4.
- CARMIGNANI L., ANTONPAOLI M.L., FANTOZZI P.L. & MECCHERI M. (2003) - *Studi conoscitivi sui bacini marmiferi industriali di Carrara: un contributo per la gestione pianificata dell'attività. Tav. 3 - Carta delle varietà merceologiche dei bacini marmiferi del Carrarese. Tav. 4 - Sezioni geologiche dei marmi del Carrarese.*
- Quad. Studi Docum., 24, Suppl. GEAM, Anno XXXIX/4.
- COLI M. (1991) - *L'escavazione del Marmo di Carrara nell'ambito del Parco Regionale delle Alpi Apuane: una convivenza problematica.* In "L'attività estrattiva nelle nostre montagne", Atti 2° Conv. Geoling., Ass. Min. Sub., 61-72.
- COLI M. (1992) - *Carta strutturale del bacino marmifero di Boana (Alpi Apuane).* S.EL.C.A. Firenze.
- COLI M. & FAZZUOLI M. (1992) - *Considerazioni sulla litostratigrafia e sull'evoluzione sedimentaria delle formazioni retico-liassiche del nucleo metamorfico apuano.* Atti Tic. Sc. Terra, **32**, 43-60.
- COLI M. & GRANDINI G. (1994) - *Evoluzione e compatibilità ambientale dell'attività estrattiva del Marmo di Carrara.* Ass. Min. Sub., GEAM, **83**, 111-116.
- COLI M., GRANDINI G. & MATTEINI L. (1987) - *Carta strutturale del bacino marmifero di Orto di Donna (Alpi Apuane).* S.EL.C.A. Firenze.
- COLI M., GRANDINI G. & MATTEINI L. (1988) - *Il bacino marmifero di Orto di Donna (Alpi Apuane). Aspetti geologici, morfotettonici, strutturali e tecnici dei Marmi di Orto di Donna.* Copist. San Gallo, Firenze.
- CRISCI G. LEONI L. & SBRANA A. (1975) - *La formazione dei Marmi delle Apuane (Toscana). Studio petrografico, mineralogico e chimico.* Atti Soc. Tosc. Sc. Nat., Mem. Ser. A, **82**, 289-298.
- DOLCI E. (1980) - *Carrara cave antiche.* Comune di Carrara.
- E.R.T.A.G. (1980) - *I Marmi apuani: schede merceologiche.* Regione Toscana, Nuova Grafica Fiorentina, Firenze.
- FORNARO M. & BOSTICCO L. (1998) - *Le cave sotterranee di pietra in Italia. Aggiornamento e prospettive.* GEAM. Anno XXXV n. 1, pp. 21 – 26.
- MECCHERI M. (2000) - *I marmi del Carrarese: carta geologico-strutturale delle varietà merceologiche.* Atti Conv. "Le Cave di Pietre Ornamentali", Torino, 28-29 Novembre 2000, 79-86.
- MOLLI G., HEILBRONNER PANOZZO R. & WITTENSOLDENER V. (1997) - *Microstructural features of naturally deformed Alpi Apuane marbles: an introduction.* In: "Conference on deformation mechanism in nature and experiment", Basel, 17-19 March, Volume Abstract, 45-46.
- MOLLI G. & HEILBRONNER R. (1999) - *Microstructures associated with static and dynamic recrystallization of Carrara marbles (Alpi Apuane, NW Italy).* *Geologie and Mijnbouw*, **78**, 119-126.
- MOLLI G., CONTI P., GIORGETTI G., MECCHERI M. & OESTERLING N. (2000) - *Microfabric study on the deformational and thermal history of the Alpi Apuane marbles (Carrara marbles), Italy.* *Journal of Structural Geology*, **22**, 1809-1825.
- RAMSAY J.G. & HUBER M.I. (1983) - *The techniques of modern structural geology. Vol. 1: strain analysis.* Acad Press, 1-307.
- PRIMAVORI P. (1999) - *Pianeta Pietra.* Giorgio Zusi Editore, Verona.
- PRIMAVORI P. (2000) - *Il "verso".* MARMOMACCHINE, **152**, 78-128.
- PRIMAVORI P. (2002) - *Evoluzione tecnologica e situazione attuale di macchine e impianti per l'escavazione e la trasformazione dei materiali lapidei.* In: DIRECTORY MARMOMACCHINE, Milano, 40-196.
- PRIMAVORI P. (2004) - *Tecnologie e metodologie di estrazione nelle cave di lapidei ornamentali.* In: DIRECTORY MARMOMACCHINE, Milano, 52-235.
- ZACCAGNA D. (1932) - *Descrizione geologica delle Alpi Apuane.* Mem. Descr. Carta Geol. d'Italia, **25**, 1-440.